

NB/NHB PORTABLE BALANCE



► FEATURES

- 7 keys embossed membrane keyboard
- Percentage weighing, counting, accumulation
- Selectable weighing unit
- Standard RS-232 interface
- Attached wind shielding ($\leq 1500g$)

► OPTIONS

- Below weighing
- USB interface
- ~~Blue-tooth~~

► DIMENSION (mm)

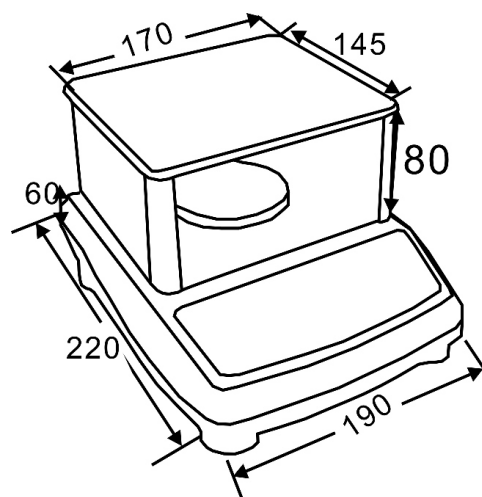

► SPECIFICATIONS

Model	NB	NHB	NHB+
Display	16.5mm LCD, With white color LED backlight		
Operate temp	0°C~+40°C		
ADC	sigma delta		
ADC update	$\leq 1/10$ second		
Housing	ABS plastic		
Max. Divisions	30,000	60,000	150,000
Power	AC adapter(9V/800mA), Rechargeable battery (6V/1.2Ah)		
Pan size	Round 80mm(150g), 120mm (300~1500g), square 140x150mm (≥ 1500)		
Capacities	300g/600g/1500g/3000g/6000g		150g/1500g
Gross weight	Capacities $\leq 1500g$ --- 2.9kg		Capacities $> 1500g$ --- 2.7kg
Packing	Master carton 4 in 1 packing, dimension 0.122 m ³ , 40 feet container can load 1760 machine, 20 feet container can load 880 machine		